

LINEAR FAN COIL DIFFUSERS

Models LCD



AIR IN MOTION

Contents

	Page
Introduction	Page 3
Product Specification – Diffuser	Page 4
Product Specification – Plenum Box	Page 5
Selection Guide	Page 6
Selection Nomogram	Page 7
Dimension Data - Diffuser	Page 8
Dimension Data – Plenum Box	Page 9
Installation Methods	Page 10
Ordering Information	Page 11

Introduction

The Model LCD fixed blade linear ceiling diffuser is designed to provide 1 or 2 way direction, while capable of a high air volume. Having as standard a 32mm wide flat surface flange frame with blades fixed at 45°, set on a maximum pitch of 15mm.

Model LCD is suitable for use on supply or exhaust systems. The high air volume capacity and low resistance make it ideal for use with ceiling mounted fan coil units.

A choice of individual or continuous diffuser lengths can be selected. Mitre corner sections maintain a continuous appearance.

To locate the diffuser off centre, the 2 way format blades can be arranged into an unequal split to distribute more air in one direction. The diffuser can also be used for combined supply and exhaust air applications.

An array of flange widths include the standard 32mm wide flat flange, 20mm wide flat flange or 27mm wide bevel edge flange. The standard un-drilled flange frame allows for simple lay in installation, alternatively countersunk screw holes or a concealed bracket fixing can be provided.

As standard the diffuser core is non-removable although a removable core version is available. Two types of removable core can be supplied. Either; sprung mullion removable core or screw fix removable core.

A stove enamel white or silver finish is offered as standard. Special stove enamel paint finishes or anodised finish to mechanically cleated grilles may also be provided.

Each diffuser can be fitted with an opposed blade damper,

operated by concealed screw cam accessed through the diffuser blade.

Purpose designed and individually selected plenum boxes ensure the performance and characteristics of the diffuser.

As standard the plenum box is from zintec steel with a single circular side entry spigot and is plain unlined without a spigot damper. For more critical areas a 12mm class 'O' foam internal lining can be used. Other options, such as galvanised steel material equalising grids and a range of spigot variations are also available.



Flange Options

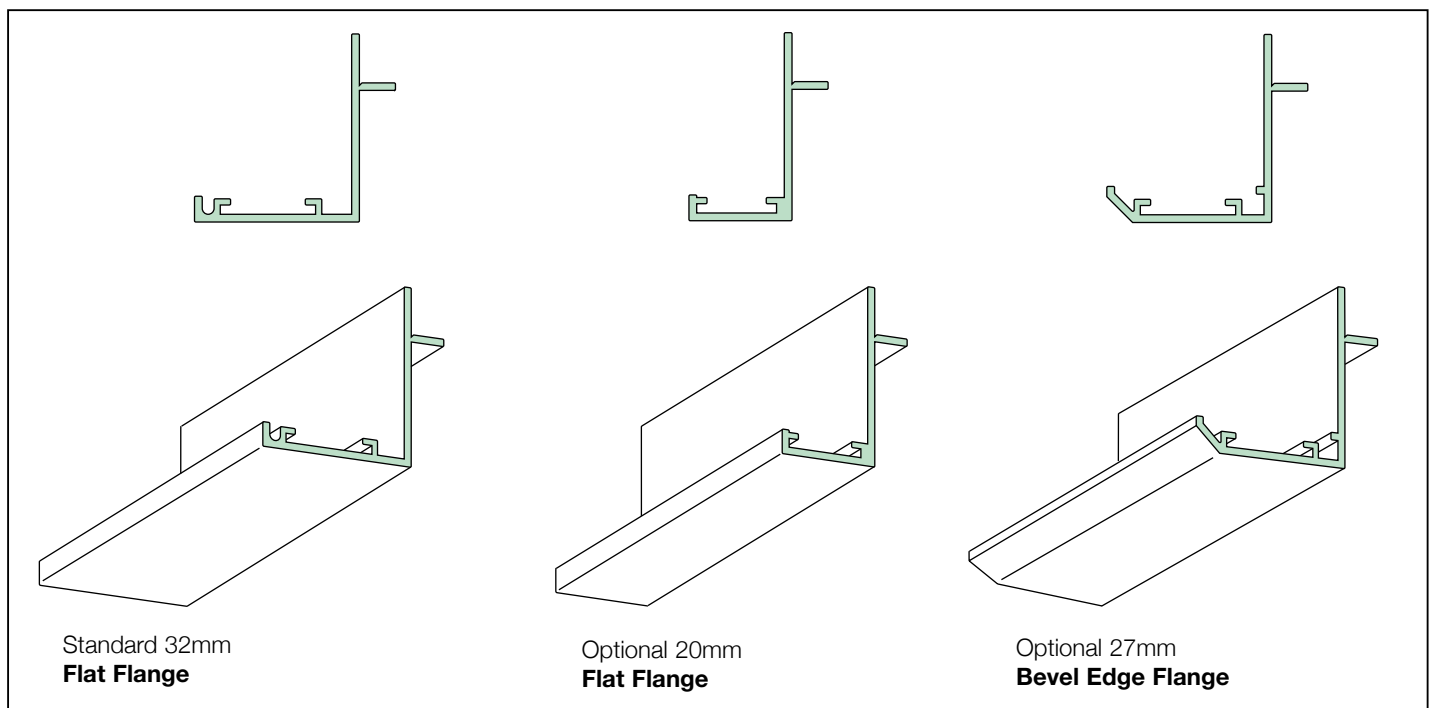

Product Specification

Diffusers

Material

Extruded aluminium.

Construction

Flange frame corners are mitred and fixed by either mechanical cleats or argon arc welding. Blades are joined by rods and tube spacers.

Frames supplied with either flat surface or bevel edge flange. Standard is 32mm flat surface flange.

Where mullions are provided the tube mullions are at approximately 350mm centres.

Individual sections are butt jointed together using joiner plates to give a continuous appearance.

Standard Installation Method

A plain undrilled flange frame allows for lay-in installation on all flanges (32mm, 27mm and 20mm). (Type FO fixing).

Installation options

Countersunk screw holes on 32mm flat flange or 27mm bevel edge flange only.

Secret Strap and Secret Strap with 'U' bracket for use on 32mm, 27mm and 20mm flange widths. (Type F4 or F6 fixing).

Spring Clips for use on 32mm, 27mm and 20mm flange widths. (Note suitable for ceiling or high sidewall type F2 fixing).

Ceiling Clips (details to be supplied i.e. type of ceiling spring tees type F8 fixing).

For more fixing details see page 10.

Accessories

Removable Core with either type F9 screw fixing or F10 spring mullion.

For details see page 8.

Separate Mitre Corner sections to maintain continuous appearance. (Corner sections only with fixed core).

Opposed Blade Dampers can be fitted to the rear of the diffuser. Operation is by concealed screw cam located through a hole provided in the diffuser blade.

Purpose designed Plenum Boxes, with either side or top entry, circular, square or rectangular spigots, can also be supplied.

Finish

Standard finish is either stove enamel White to RAL9010 (20% gloss) or Silver to RAL9006.

A full range of special stove enamel paint finishes is available on request, together with an anodised finish on mechanically cleated grilles.

Standard Model Types

LCD1G – 1 way direction diffuser only NO OBD.

LCD2G – 2 way direction (equal split) diffuser only NO OBD.

LCD1R – 1 way direction diffuser WITH OBD fitted.

LCD2R – 2 way direction (equal split) diffuser WITH OBD fitted.

Product Specification

Plenum boxes

Material

0.7mm thick zintec steel as standard or galvanised mild steel available as an option.

Construction

Fabricated in 3 sections having ends spot welded and sealed to centre section. Spigot fitted centrally in plenum length. Plenum Boxes supplied as standard with straight edges and no hem (F0), hemmed plenum edges available for use with secret fixing brackets (F6).

Standard Installation Method

The capped ends of the plenum box incorporate an indent for 8mm drop rod fixings, which allows for holes to be drilled without disturbing the active section,

Installation options

Fixing lugs can be factory fitted if preferred or other special fixing methods may be used.

For details of plenum fixings see page 10.

Accessories

Additional circular spigots may be fitted, rectangular or square spigots are also available.

Spigot dampers include; quadrant, teleflex operation or cord operated.

12mm thick Class 'O' internal lining.

Equalising grids (50% free area mesh).

Fixing lugs or other special fixings.

Filter media installed in plenum.

Plain Ends (No Indent).

Hemmed edge plenum boxes (type F6 diffuser fixing brackets are used as standard).

Finish

Self finish zintec steel as standard.

Alternatively black paint can be applied to internal faces if required.

Standard Model Types

PBL-1 Standard unlined linear plenum box with 1 number centrally located circular side entry spigot having no damper or equalising grid.

PBL-2 Unlined plenum box with 1 number centrally located circular top entry spigot having no damper or equalising grid.

PBL-3 Unlined joggled plenum box with 1 number centrally located circular top entry spigot having no damper or equalising grid.

Selection Guide

Mitre Corners

Mitred Corners are available and are manufactured to order.
Mitres can be cut to any angle - state angle at time of order. (Fixed core only).

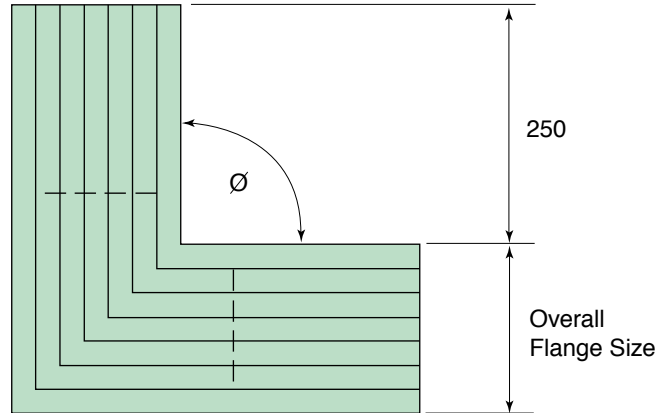

Standard Size Chart

Nominal Width	Overall Flange 32 Frame	Overall Flange 20 Frame
90	135	111
100	145	121
120	165	141
150	195	171
200	245	221
225	270	246
250	295	271
300	345	321

Selection Procedure

Establish the volume rate per linear metre. Determine whether one or two way throw is required. Obtain the available throw. Take a straight edge to the nomogram from the throw rate. Make a line through the required throw ensuring the corresponding values for sound and pressure levels do not exceed permissible limits. The nominal width is read from the point of intersection with the sizes on the far right of the nomogram.

Example

The example shows a suitable selection of a 150mm nominal width LCD2, 1 metre long handling 150l/s with a throw of 3.05 metres, with a sound level of NRLW 27 and pressure drop of 12N/m².

Pressure Drop and Sound Ratings

The pressure drop given is for supply diffuser with damper fully open. When the diffuser is installed with plenum box, the pressure loss of the box has to be added to the diffuser.

Spigot Velocity m/s	1.5	2.0	2.5	3.0	3.5	4.0
Pressure Drop Pa*	2	4	6	8	12	16
Sound Level NR*	-	-	25	30	35	40

* The figures given are approximate - dependent upon spigot entry conditions.

Plenum Box Spigot Volumes

Diameter (mm)	Spigot velocity m/s					
	1.5	2.0	2.5	3.0	3.5	4.0
100	10	15	19	22	26	30
125	18	24	30	35	41	47
150	25	34	42	51	60	68
175	35	46	58	70	82	94
200	45	60	75	91	109	121
225	58	77	96	117	137	151
250	71	95	120	142	170	191
275	86	115	145	172	205	230
300	103	139	172	208	240	275
325	120	160	200	240	280	320
350	140	188	235	280	328	375
400	185	245	310	370	430	495

Selection Nomogram

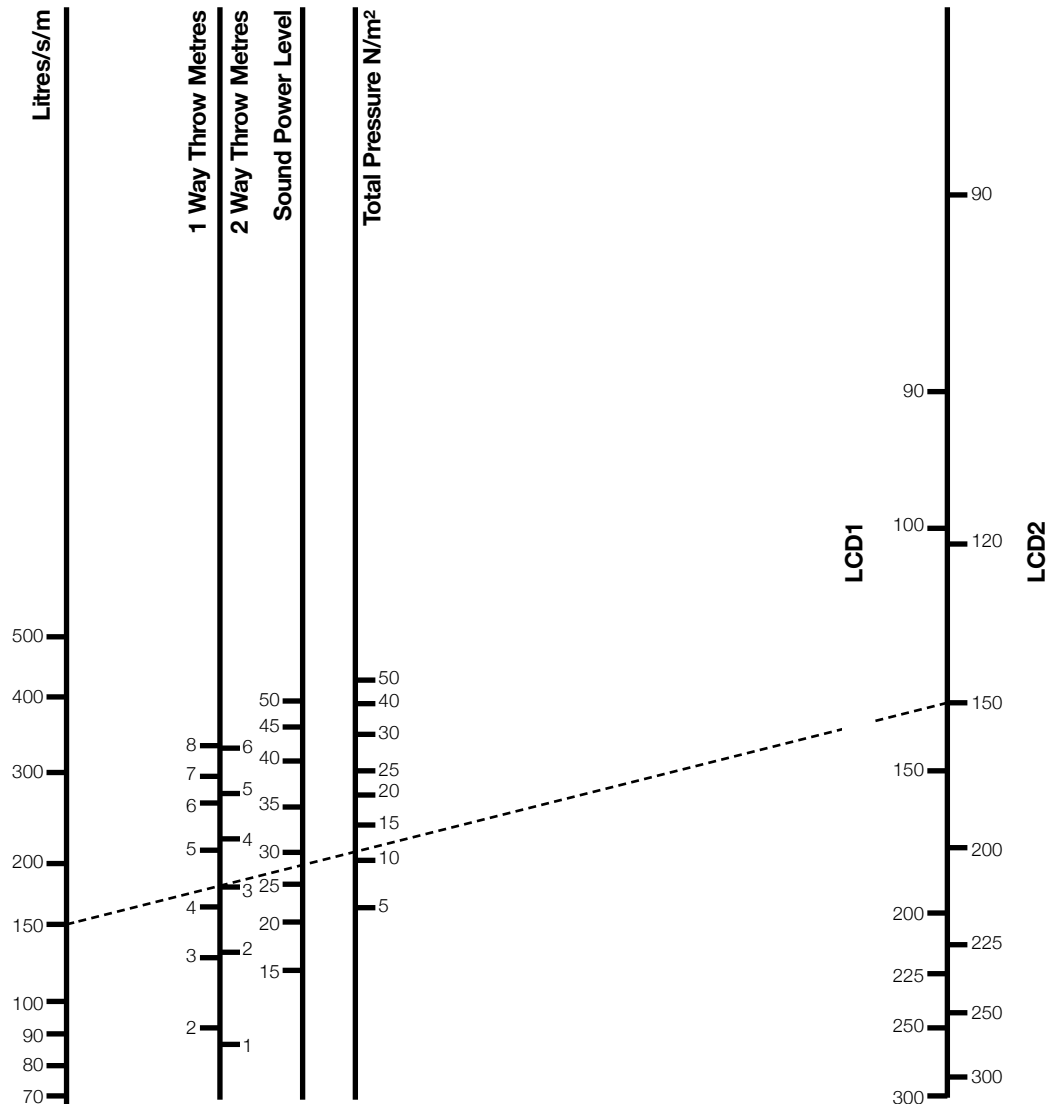

Recommended volumes for varying room heights

Depth of airstream can influence room comfort conditions when supplying cool air. The table below gives recommended volume rates for varying room heights. (Based on 10 °C cooling).

Mounting Height metres	2.3	2.5	3.0	3.5
Max. Recommended Air Flow in one direction L/s/m	40	100	200	350

Active length

Active length has an effect on performance. The nomogram is based on one metre active length. Factors below should be applied to other lengths.

Diffuser Active Length (m)	Throw Multiplier	Sound Level Correction (dB)
0.4	0.6	-4
0.5	0.7	-3
1.0	1.0	0
1.5	1.15	+2
2.0	1.25	+3
3.0+	1.3	+5

Throw is based on a terminal velocity of 0.5m/s

Diffuser Dimension Data

Model LCD 1R

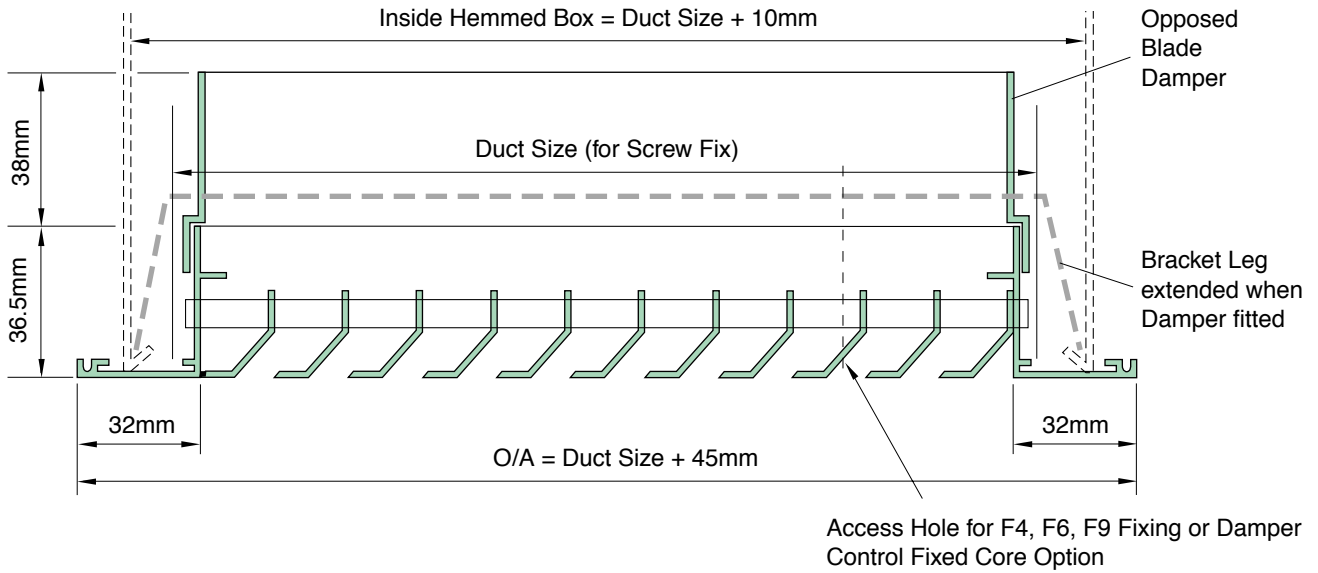

Model LCD 2R

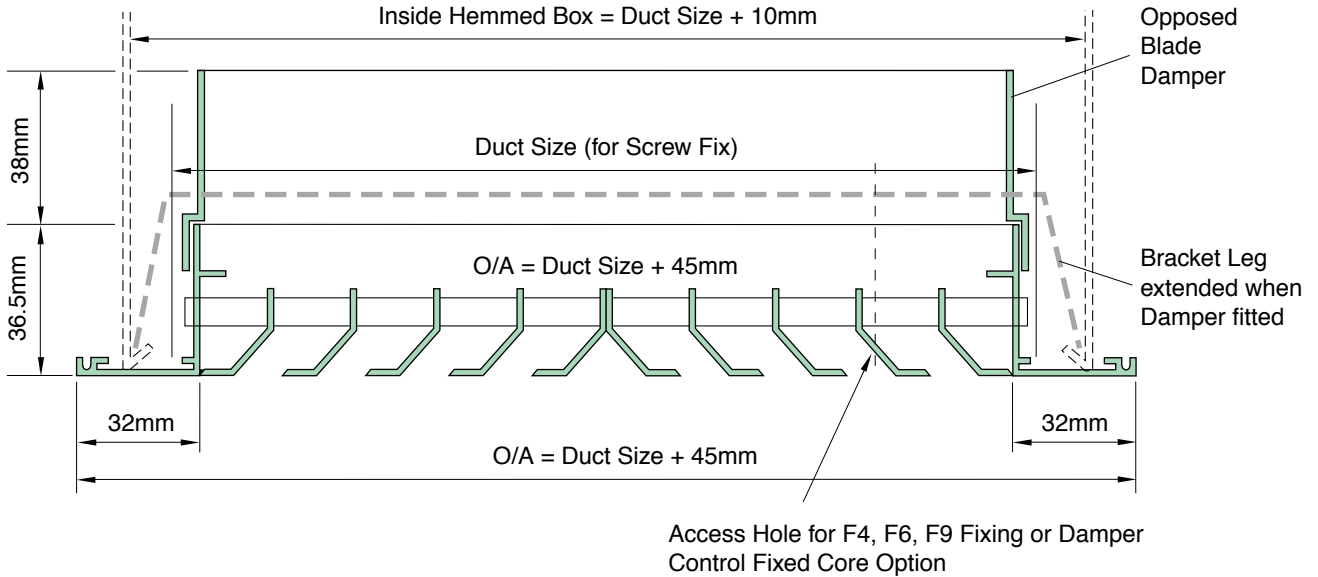

Box Hem Detail

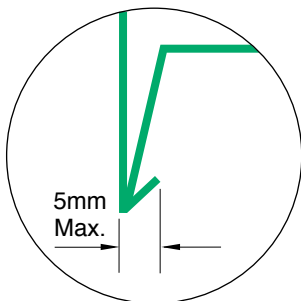

Alternative Flange Size

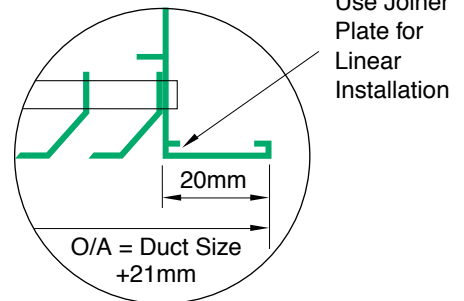

Note: Duct Size = Nominal Size

Plenum Box Dimensions

Type PBL-1

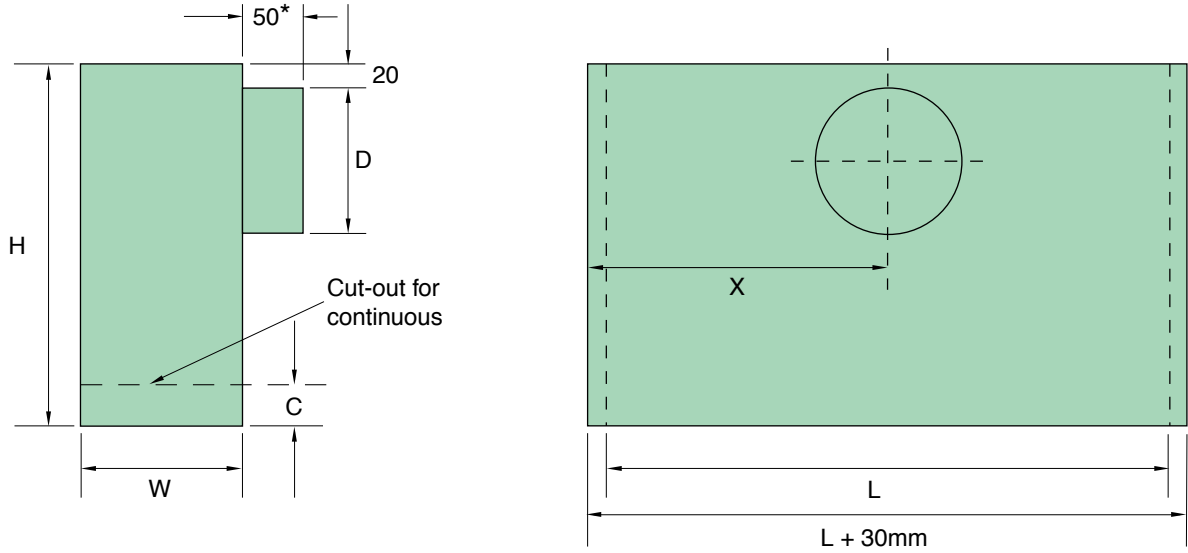

* This becomes 'D' if spigot damper fitted

Order Detail

H	L	W	D	C		X
				LH	RH	
-	-	-	-	-	-	-

Type PBL-1 for F6 fixing

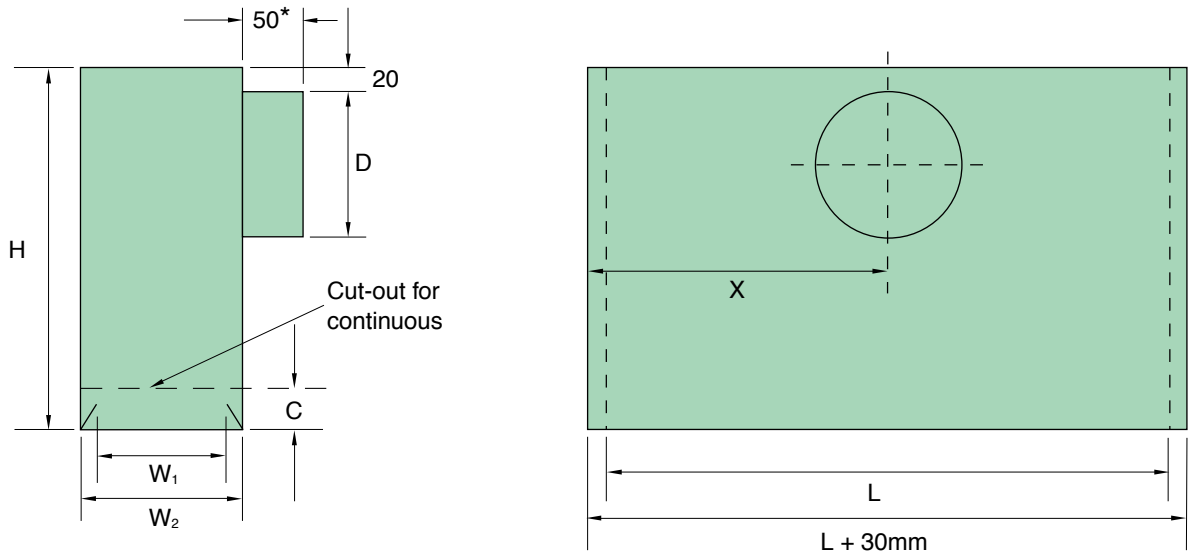

* This becomes 'D' if spigot damper fitted

Order Detail

H	L	W ₀	W ₁	D	C		X
					LH	RH	
-	-	-	-	-	-	-	-

Boxes shown have Indented End. Plain End Boxes are available on request.

Installation Methods

Fixing Details

Type F1

Standard face countersunk holes for screw fixing.

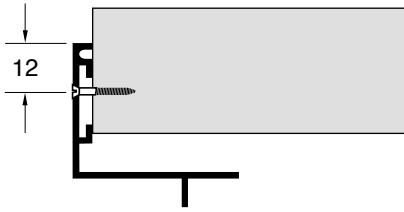

Type F2

Optional spring clips

Note: For satisfactory fixing - requires accurately formed opening or duct with firm sides. Not suitable for ceiling or high sidewall installation.

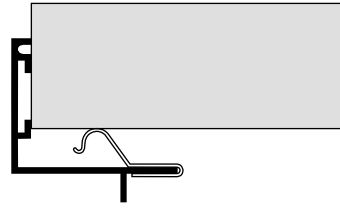

Type F4 - Fixed Core

Optional rear strap

Note: Mating strap by others.

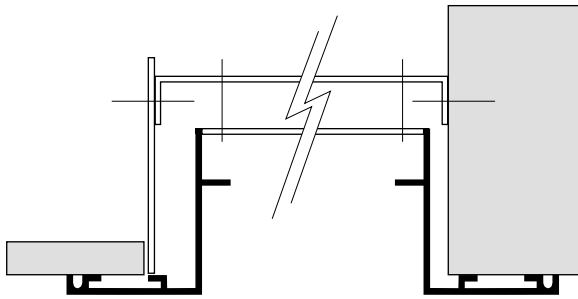

Type F6 - Fixed Core

Optional rear strap + mating 'U' bracket

Note: Hemmed duct by others or plenums by us.

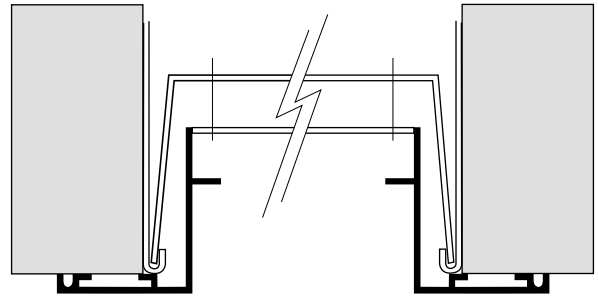

Fixing Detail for Grilles

Type F9 - Removable Core Screw Fix

Screw through strap on core into strap on outer flange

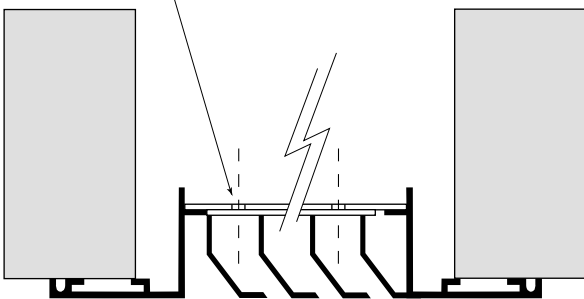

Type F10 - Removable Core Sprung Mullion

First Blade held fixed

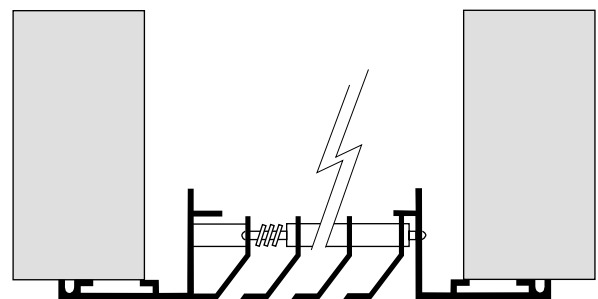

Ordering Information

Example

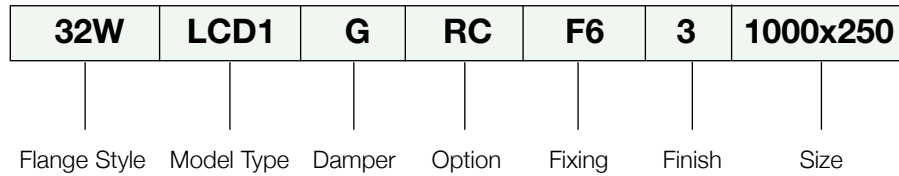

Diffuser Available Options

Flanges

- 20W** 20mm flange with mitred and welded corners
- 20C** 20mm flange with mitred and mechanically cleated corners
- 27BW** 27mm Bevel edge flange with mitred and welded corners
- 27BC** 27mm Bevel edge cleated construction
- 32W** 32mm flat surface flange with mitred and welded corners
- 32C** 32mm flat surface flange with mitred and mechanically cleated corners

Model Type

- LCD1** One-Way Linear Ceiling Diffuser
- LCD2** Two-Way Linear Ceiling Diffuser

Damper

- R** Registers (diffusers with dampers)
- G** Diffusers only

Options

- RC** C/W Removable Core
- FC** Fixed Core

Fixing

- F0** No fixing (e.g. for 'lay-in' fixing or where fixing holes are drilled on site)
- F1** Countersunk screw fixing holes in flanges (32C, 32W only – not available on 20C, 20W)
- F2** Spring clip (not suitable for high sidewall or ceiling)
- F4** Secret Strap – mating strap in duct or opening provided by others
- F6** Secret Strap with 'U' bracket – normally requires internally hemmed duct edge by others – or we can provide plenum boxes with the required hem feature.
- F8** Spring clip (detail to be supplied, i.e., type of ceiling, spring tee)
- F9** Removable core - Screw fix
- F10** Removable core - Sprung mullion

Finish

There are a large number of finish options as indicated below:

- 0** Mill extruded aluminium
- 1** Natural anodised aluminium frame (only available with mechanically cleated corners)
- 2** Silver baked enamel finish RAL 9006
- 3** White RAL 9010 eggshell finish (20% gloss)
- 4** Black eggshell finish
- 5** Brushed (linished) natural aluminium face surfaces
- 6** Special finish to be specified external to the model reference

Where more than one special finish is required, consecutive numbers above 6 are used with an explanatory key

Plenum Box

Model

- PBL-1** Standard linear plenum box with circular side entry spigot.
- PBL-2** Linear plenum box with circular top entry spigot.
- PBL-3** Joggled linear plenum box with circular top entry spigot.
- SPB** Special plenum box.

Spigot

- Standard 1 Circular spigot.
- Spigot diameter.
- Additional circular spigot.
- Special spigot type or location.

Type

- U** Standard unlined plenum box.
- L** Fitted with 12mm thick Class 'O' internal lining.
- P** Internal faces plenum faces painted black.

Option

- O** Standard No equalising grid.
- G** Fitted with 50% free area equalising mesh (below spigot entry).

Damper

- ND** Standard No Damper.
- QD** Quadrant damper in spigot.
- TF** Teleflex damper operation.
- CD** Cord operated damper.

Accessories

- FL** Fixing lugs fitted to sides of plenum box.
- AP** Access panel fitted to side of plenum box.
- SF** Special fixings.
- F** Filter media required.
- PE** Profile ends fitted to each plenum box end.



JPR Services - Weltech Business Centre - Ridgeway - Welwyn Garden City - Herts AL7 2AA
Tel: 01707 871526 - Fax: 01707 871527 - email sales@jprservices.co.uk - www.jprservices.co.uk